

SIGNODE **HBX-4300**™ **LARGE** **FRAME**

Semiautomatic plastic strapping machine



- **Unmatched simplicity**
Easy to operate and maintain
- **Jam-resistant technology**
- **Bi-directional coil loading**
- **Strap alignment laser option**

Model is shown with optional features.

Up to 50 straps per minute!

SIGNODE®

SIGNODE HBX-4300™ LARGE FRAME

Semiautomatic plastic strapping machine

The HBX-4300 Large Frame semiautomatic strapping machine, ideal for oversized products, simplifies operation and maintenance to save you time and money.

Unmatched simplicity

The HBX-4300's simple yet durable design eliminates the use of drive belts and clutches. This combined with other trouble-free maintenance elements like toolless hot knife removal and jam-resistant technology make it easier to operate and more cost effective to maintain than other strapping machines.

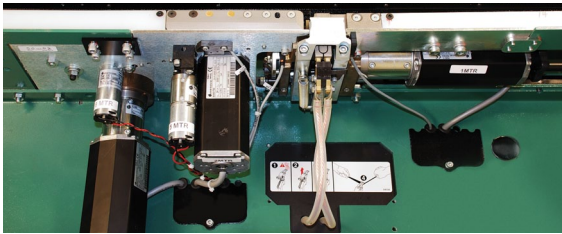

Bi-directional coil loading

Strap coil pays off from either direction, eliminating the downtime and material waste resulting from incorrect coil loading.

Out-of-strap feature

The out-of-strap feature ejects the strap at the end of the coil to eliminate downtime and errors associated with removing the excess strap left in the machine.

Fully accessible strap path

No tools required. Simply raise the tabletop and lift guide for access to strap path.



High joint efficiency

The HBX-4300 Large Frame strapping machine can utilize either Contrax® polypropylene or Tenax® polyester strapping. Both provide high retained tension and joint efficiency to maximize package performance.

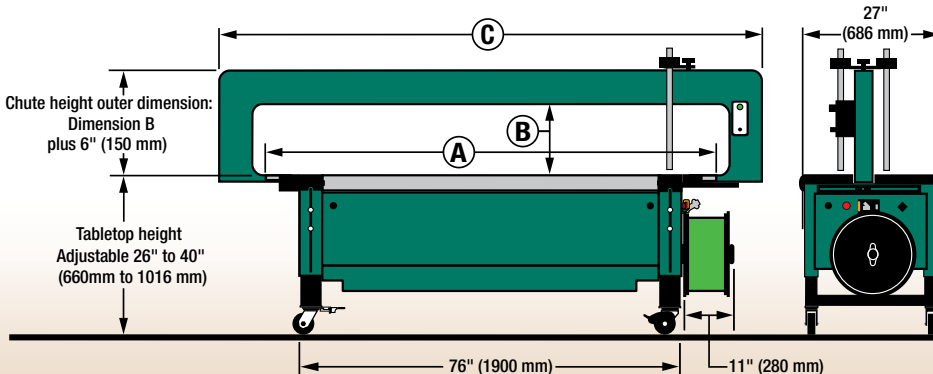

Options:

Automatic cut-off and refeed

Signode's patented automatic cut-off and refeed feature automatically ejects misfed strap, rethreads itself and continues strapping without operator intervention.

Adjustable package guides

Ideal for oversized applications, adjustable package guides help keep boxes square during strapping.



Strap alignment laser

For applications where strap placement must be precise, a laser beam indicates the exact location of strap placement prior to strapping.

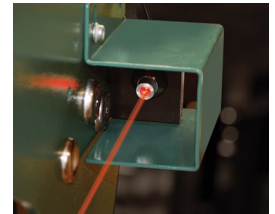

HBX-4300 Large Frame specifications

Cycle rate: Up to 50 straps per minute. Actual production will vary depending on package size, chute size and operator dexterity.

Maximum package weight: 100 lbs on machine or conveyor

Maximum applied tension: Up to 250 lbs (1110 N)

Strapping: 9 mm or 12 mm Contrax® polypropylene or Tenax® polyester strapping

Electrical requirements:

120 volt, 60Hz, FLA 7 amp; 3 phase voltage optional

Shipping weight: 1,100 lbs

HBX-4300 Large Frame options

- Automatic cut-off and refeed
- Adjustable package guides
- Strap alignment laser
- Floor lock kit
- Footswitch
- Indicator light to alert operator to low strap/out-of-strap conditions and machine malfunction
- Conveyor interlock kit

HBX-4300 Large Frame chute dimensions

	inches	mm	inches	mm
A	65	1650	90	2285
B	20	510	15	380
C	78	1980	107.5	2730

SIGNODE INDUSTRIAL GROUP
3610 West Lake Avenue
Glenview, Illinois 60026
1-800-323-2464
www.signode.com