

# **SIGNODE** **HBX-4300**<sup>TM</sup>

**Semiautomatic plastic strapping machine**

- **Unmatched simplicity**  
*Easy to operate and maintain*
- **Jam-resistant technology**
- **Bi-directional coil loading**



**Up to**  
**70**  
**straps per**  
**minute!**

Model is shown with optional features.

**SIGNODE**<sup>®</sup>

# SIGNODE HBX-4300™

## Semiautomatic plastic strapping machine

The new HBX-4300™ semiautomatic strapping machine is the simplest, most reliable general-duty strapping machine on the market today. With 40% fewer parts and more timesaving features, the HBX-4300 machine simplifies operation and maintenance to save you time and money.

### Unmatched simplicity

The HBX-4300's simple yet durable design eliminates the use of drive belts and clutches. This combined with other trouble-free maintenance elements like toolless hot knife removal and jam-resistant technology make it easier to operate and more cost effective to maintain than other strapping machines.

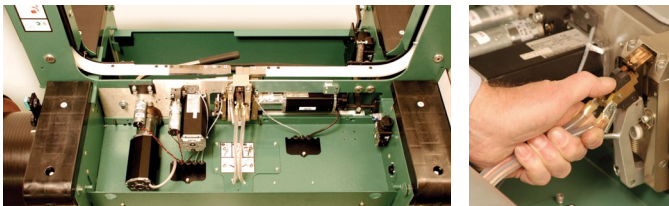

### Bi-directional coil loading

Strap coil pays off from either direction, eliminating the downtime and material waste resulting from incorrect coil loading.

### Out-of-strap feature

The out-of-strap feature ejects the strap at the end of the coil to eliminate downtime and errors associated with removing the excess strap left in the machine.

### Fully accessible strap path

No tools required. Simply raise the tabletop and lift guide for access to strap path.



### Automatic cut-off and refeed option

Signode's patented automatic cut-off and refeed feature automatically ejects misfed strap, rethreads itself and continues strapping without operator intervention.

### Small Anvil machine

The HBX-4300 Small Anvil machine is designed to accommodate packages as small as 2-3/4" (70 mm) wide by 3/4" (19 mm) high. This machine is only available in a 16" x 10" (405 mm x 255 mm) chute size.

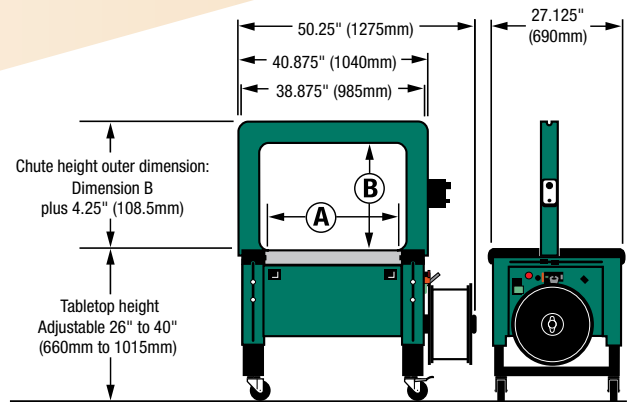

HBX-4300 Chute inner dimensions

	inch	mm	inch	mm	inch	mm	inch	mm
A*	16	405	20	510	28	710	33	840
B	10	255	15	380	20	510	30	760

\*Inner dimension A is maximum package size.

### HBX-4300 Specifications

**Cycle rate:** Up to 70 straps per minute. Actual production will vary depending on package size, chute size and operator dexterity.

**Maximum package weight:** 100 lbs

**Maximum applied tension:** Up to 250 lbs (1110 N)

**Strapping:** 9 mm or 12 mm Contrax polypropylene strapping

**Electrical requirements:** 120 volt, 60Hz, FLA 7 amp;  
3 phase voltage optional

**Shipping weight:** 600 lbs

### HBX-4300 Options

- Automatic cut-off and refeed
- Conveyor interlock kit
- EZ clear button
- EZ height adjustable leg kit — 26" to 40" (660 mm to 1015 mm)
- Floor lock kit
- Indicator light alerts operator to low strap/out-of-strap conditions and machine malfunction
- Roller top
- Single or dual compression  
Single: Up to 120 lbs at 90 lbs psi  
Dual: Up to 240 lbs at 90 lbs psi

**The HBX-4300 is also available in a stainless steel model as well as an automatic model, the HBX-4330.**

**SIGNODE INDUSTRIAL GROUP**  
3610 West Lake Avenue  
Glenview, Illinois 60026  
1-800-323-2464  
www.signode.com