

SIGNODE **HBX-4330**TM **STAINLESS** **STEEL**

Automatic stainless steel plastic strapping machine

**Reliable
packaging
under harsh
conditions**

for the
**Meat, Poultry
and Seafood**
industries



Up to 70 straps per minute!

SIGNODE[®]

SIGNODE HBX-4330™ STAINLESS STEEL

Automatic stainless steel plastic strapping machine

The new HBX-4330™ automatic strapping machine is the simplest, most reliable general-duty strapping machine on the market today. With 40% fewer parts and more timesaving features, the HBX-4330 machine simplifies operation and maintenance to save you time and money.

Unmatched simplicity

The HBX-4330's simple yet durable design eliminates the use of drive belts and clutches. This combined with a number of other features make it easier to operate and maintain than other strapping machines.

- Jam-resistant technology
- Bi-directional coil loading
- Out-of-strap feature
- Fully accessible strap path
- Toolless hot knife and conveyor removal
- Automatic cut-off and refeed option
- Variable speed conveyor

Reliable packaging

Designed for reliable packaging under harsh conditions, the HBX-4330 is built with a number of stainless steel components, making it ideal for packaging applications where corrosion resistance is necessary.

Stainless steel components

- Frame
- Rear panels
- Dispenser door
- Legs
- Slack box
- Electrical door

Save on strapping costs with the HB Series plastic strapping

The new HBX-4330 utilizes Signode's newest Contrax® polypropylene strapping. HB Series strapping has the same durable properties as regular Contrax with more strap per coil.

- HB 612 9 mm Contrax coils – 16,000 feet per coil
- HB 812 12 mm Contrax coils – 12,000 feet per coil

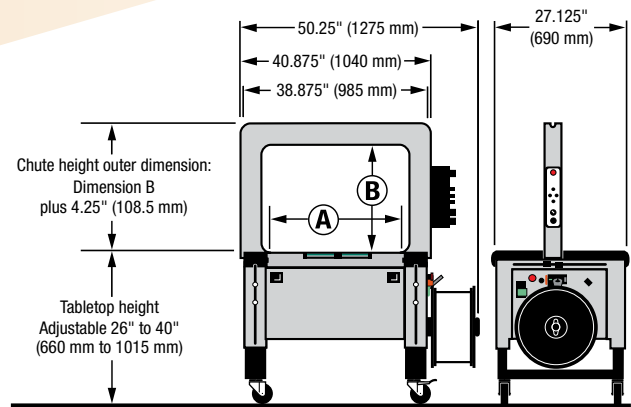

HBX-4330 Chute inner dimensions

	in.	mm
A*	28	710
B	20	510

*Inner dimension A is maximum package size.

HBX-4330 Specifications

Cycle rate: Up to 70 straps per minute. Actual production will vary depending on package size, chute size and operator dexterity.

Maximum package weight: 100 lbs on machine or conveyor

Strapping: 9 mm or 12 mm Contrax polypropylene strapping

Electrical requirements:

120 volt, 60Hz, FLA 9.0 amp; 208 volt, 60Hz, FLA 5.2 amp;

230 volt, 60Hz, FLA 4.7 amp; 460 volt, 60Hz, FLA 2.3 amp;

575 volt, 60Hz, FLA 2.0 amp

Shipping weight: 600 lbs

HBX-4330 Options

- Single or dual compression
Single: Up to 120 lbs at 90 lbs psi
Dual: Up to 240 lbs at 90 lbs psi
- Indicator light alerts operator to low strap/out-of-strap conditions and machine malfunction
- EZ height adjustable leg kit — 26" to 40" (660 mm to 1015 mm)
- Automatic cut-off and refeed
- Dual photo eye
- Conveyor interlock kit

The HBX-4330 is also available in a semiautomatic model, the HBX-4300.

SIGNODE INDUSTRIAL GROUP
3610 West Lake Avenue
Glenview, Illinois 60026
1-800-323-2464
www.signode.com