

SIGC SERIES

Automatic Corrugated Bundler

High speed bundling. Operator-friendly design.



Versatile

For strapping flexo-folder corrugated products and more.

Operator-friendly, intuitive controls

Fast bundle size set up.

Maximum uptime

Automatic strap loading and refeed technology for ultimate performance and continuous strapping. Patented easy access strap guides for fast troubleshooting and no tools required.

Reduce downtime

Less strap coil change overs. The only machine in the corrugated industry that accepts 40k XL coils.

Lowest total cost of ownership

Robust machine design and low maintenance simplicity. All metal strap chute with minimal wear parts.

High speed bundling

Up to 32 bundles per minute.

SIGNODE®

Automatic Corrugated Bundler

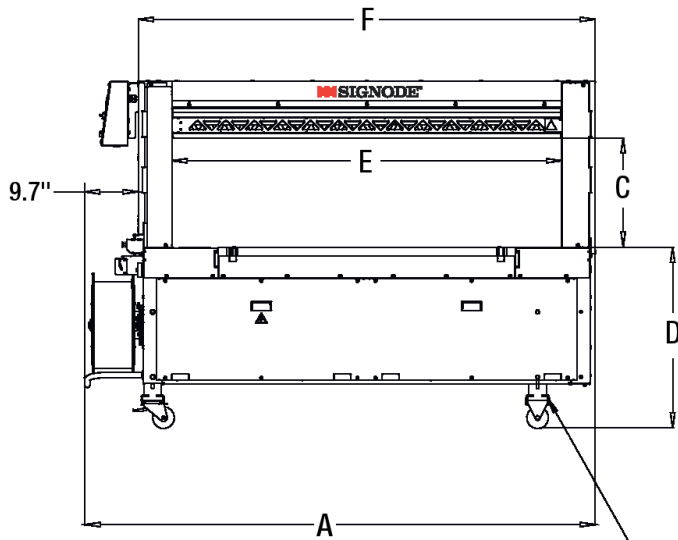

Power & Pneumatic Connections

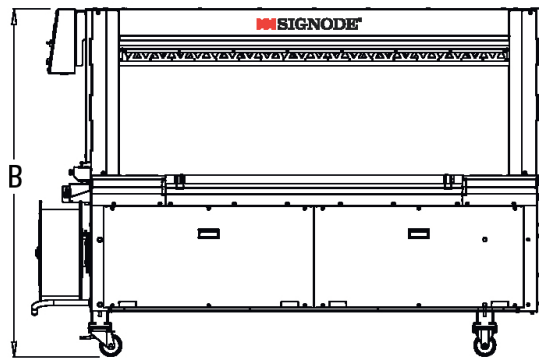
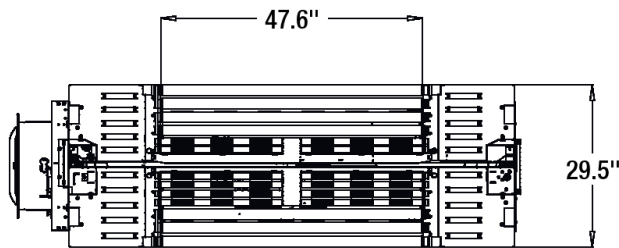
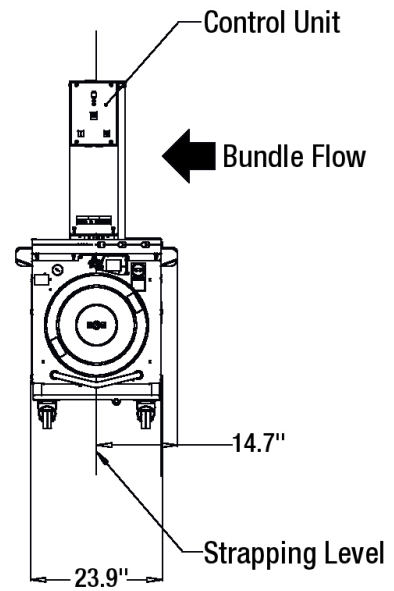

Dimensions

		SIG-C 1650	SIG-C 1250
Frame size W x H		65" x 20"	50" x 20"
Part number		x47515	x46000
Total width including strap coil	A	93"	77"
Total height	B	61.5" to 70.5"	
Inner frame height with press bar	C	19.7"	
Table top height	D	31" to 40"	
Inner frame width	E	71.0"	55.0"
Arch width	F	83.1"	67.3"
Weight		1000 lbs.	895 lbs.
Bundle width		4" to 65"	4" to 49"
Bundle height		0.3" to 18.8"	
Bundle length (min)		6"	
Bundle weight (max)		110 lbs.	

Standard Features

- Dual compression - accurate strap placement
- Signal lights with low strap indicator
- Conveyor interlocks
- Low tension strap ejector
- Automatic strap refeed

Machine Options

- Spare magnetic strap dispenser
- Spare parts kit
- Industrial interlock kit

Specifications

Cycle rate per minute (max)	Up to 32 bundles
Conveyor speed	Variable from .65 to 3.2 ft/sec
Strap tension	Variable up to 70 lbs.
Strap material	Polypropylene 5mm embossed
Strap seal method	Heat seal
Electrical requirement	460 Volt, 16 AMP, 60 Hz
Pneumatic requirement	90 psi
Pneumatic consumption	244 cubic inch per cycle (free air)
Environmental condition	40° to 110° (Fahrenheit)

SIGNODE INDUSTRIAL GROUP

3700 West Lake Avenue Glenview, IL 60026 U.S.A.
(800)323-2464 www.signode.com