

SIGVCS SERIES

Automatic Corrugated Squaring Bundler

High speed bundling. Operator-friendly design.



Equipped with . . .

SIGVIEW

The icon driven HMI control panel

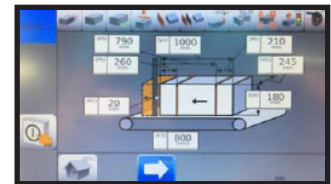

Versatile

For strapping flexo folder corrugated products and more.

Operator-friendly, intuitive controls

Format change in less than 1 minute.

Maximum uptime

Automatic strap loading and refeed technology for ultimate performance and continuous strapping. Patented easy access strap guides for fast troubleshooting and no tools required.

Reduce downtime

Less strap coil change overs. The only machine in the corrugated industry that accepts 40k XL coils.

Lowest total cost of ownership

Robust machine design and low maintenance simplicity. All metal strap chute with minimal wear parts.

High speed bundling

Up to 25 bundles per minute.

SIGNODE®

SIGVCS SERIES

Automatic Corrugated Squaring Bundler

SIGNODE®

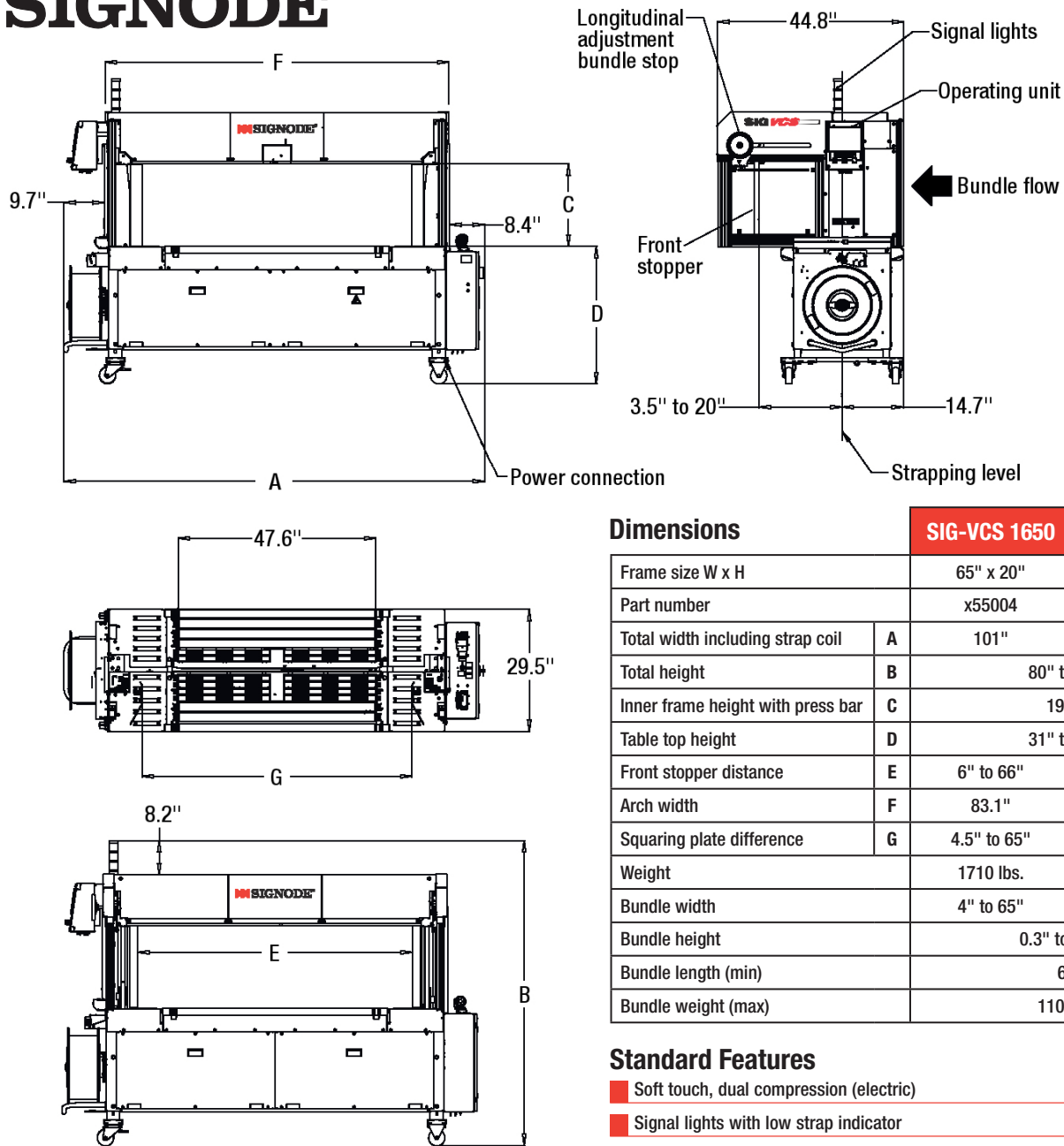

Dimensions

		SIG-VCS 1650	SIG-VCS 1250
Frame size W x H		65" x 20"	50" x 20"
Part number		x55004	x49715
Total width including strap coil	A	101"	85.5"
Total height	B	80" to 89"	
Inner frame height with press bar	C	19.7"	
Table top height	D	31" to 40"	
Front stopper distance	E	6" to 66"	6" to 50"
Arch width	F	83.1"	67.3"
Squaring plate difference	G	4.5" to 65"	4.5" to 49"
Weight		1710 lbs.	1445 lbs.
Bundle width		4" to 65"	4" to 49"
Bundle height		0.3" to 18.8"	
Bundle length (min)		6"	
Bundle weight (max)		110 lbs.	

Standard Features

- Soft touch, dual compression (electric)
- Signal lights with low strap indicator
- Conveyor interlocks
- End-of-strap monitoring with auto ejection
- 3.5" Front bundle stops and 6" Side squaring plates
- Low tension strap ejector
- All-electric design

Machine Options

- Spare magnetic strap dispenser
- Spare parts kit
- Industrial interlock kit

Specifications

Cycle rate per minute (max)	Up to 32 bundles without squaring Up to 25 bundles with squaring
Conveyor speed	Variable from .65 to 3.2 ft/sec
Strap tension	Variable up to 70 lbs.
Strap material	Polypropylene 5mm embossed
Strap seal method	Heat seal
Electrical requirement	460 Volt, 16 AMP, 60 Hz
Environmental conditions	40° to 110° (Fahrenheit)

SIGNODE INDUSTRIAL GROUP

3700 West Lake Avenue Glenview, IL 60026 U.S.A.
(800) 323-2464 www.signode.com