

VSM-Z20

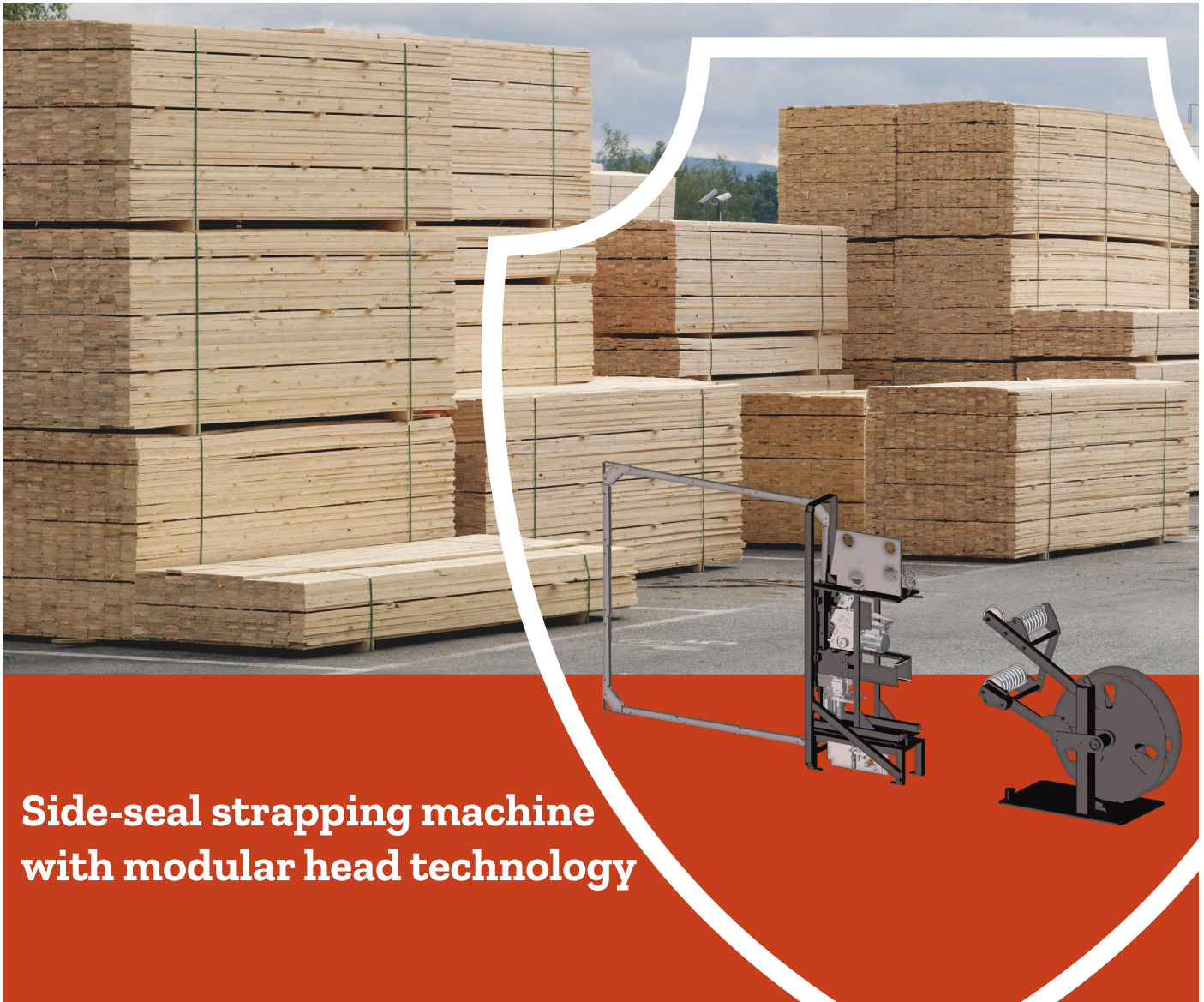

Side-seal strapping machine with modular head technology

Optimize Performance

For maximum flexibility, highest productivity and performance

Enhance Flexibility

Modular design allows use of various strapping head types

High Speed Productivity

Automatic strap feed and take-up with smart dispenser

Low Cost Ownership

Robust machine design with low maintenance to minimize costs

VSM-Z20

Side-seal strapping machine with modular head technology



VSM Machine / Features and Benefits

- **High reliability and flexibility**
Heavy duty machine frame design. Low-wear, stainless steel chute gates.
- **Easy to service and low ownership cost**
Few wearing parts, easily exchangeable. Direct brushless drives for head carriage, and bayonet for less service needs and longer operating life.
- **Communications**
Interface, signal exchange via potential free contacts or Profinet. All signals via potential free contacts.
- **Reduced operator training needs**
7" Siemens HMI operator touch screen for intuitive operation and simplified trouble shooting.

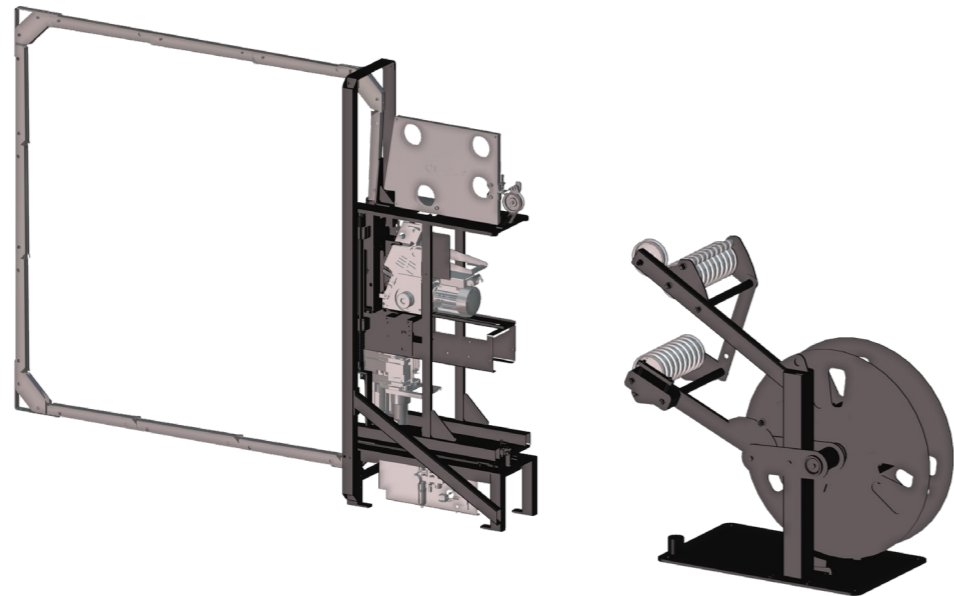

Z20 Head / Features and Benefits

- **High performance**
Head carriage mounting on side of load equipped with Z20 modular heads for high applied and retained strap tension on the load.
- **High seal efficiency**
Friction weld technology, immediately available, no pre-heating time.
- **Increased durability**
Durable and robust design and components for highest availability.
- **Reduce Downtime**
Modules can be replaced in less than one minute eliminating the need to stop production.

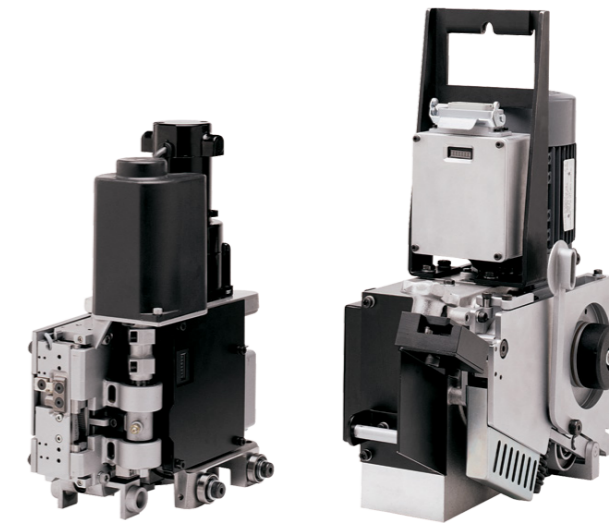

Flexible production options



Increase uptime with the optional OR-A600J multi-coil strap dispenser. Load up to six coils of strap on the rotating turntable.

Intuitive HMI display panel



An icon driven control panel that provides step by step prompts for easy set up.

Improved head carriage



The easily accessible head carriage allows easy service work when needed. Signode model Z-20 modular head technology improves performance and speed.

Jumbo strap dispenser

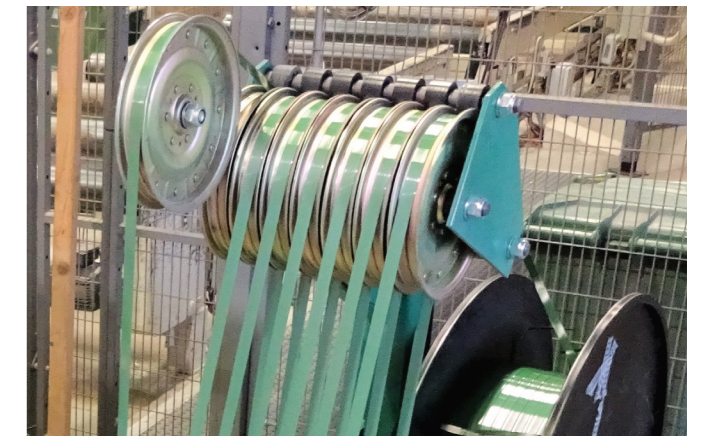

The PSD-119J jumbo dispenser is an all mechanical strap accumulator design for reliability and performance when paired with Z-20 head modules.

VSM-Z20

Side-seal strapping machine



Key Technical Specifications

Pack Width (mm)	200 - 1200
Pack Height (mm)	350 - 1200
Strap Size (mm)	16 - 19
Strap Types	Polyester
Strap Tension (N)	890 - 4450
Strap Feed Speed (m/s)	3.7
Controller	Siemens PLC S7-1200
Operator Display	7" HMI TFT Screen
Electrical Supply	400 VAC, 50 HZ, 3PE
Consumption (kVA)	2
Control voltage	24 V DC
Machine Weight	Approximately 250kg depending on options
Throughput	10 second strapping cycle *

* Performance: Depends on chute and package dimensions, conveyor speed, package distances and strap tension. Additional package and chute dimensions are available on request.

Available Options

- Indexing head carriage
- Low strap indicator
- Package pre-height dedection
- Conveyor and turntable options
- Load positioning & conveyor controls
- Machine guarding package
- Profibus DP
- Profinet
- Special color (RAL)
- Bayonet or closed-chute
- Strap end pre-warning

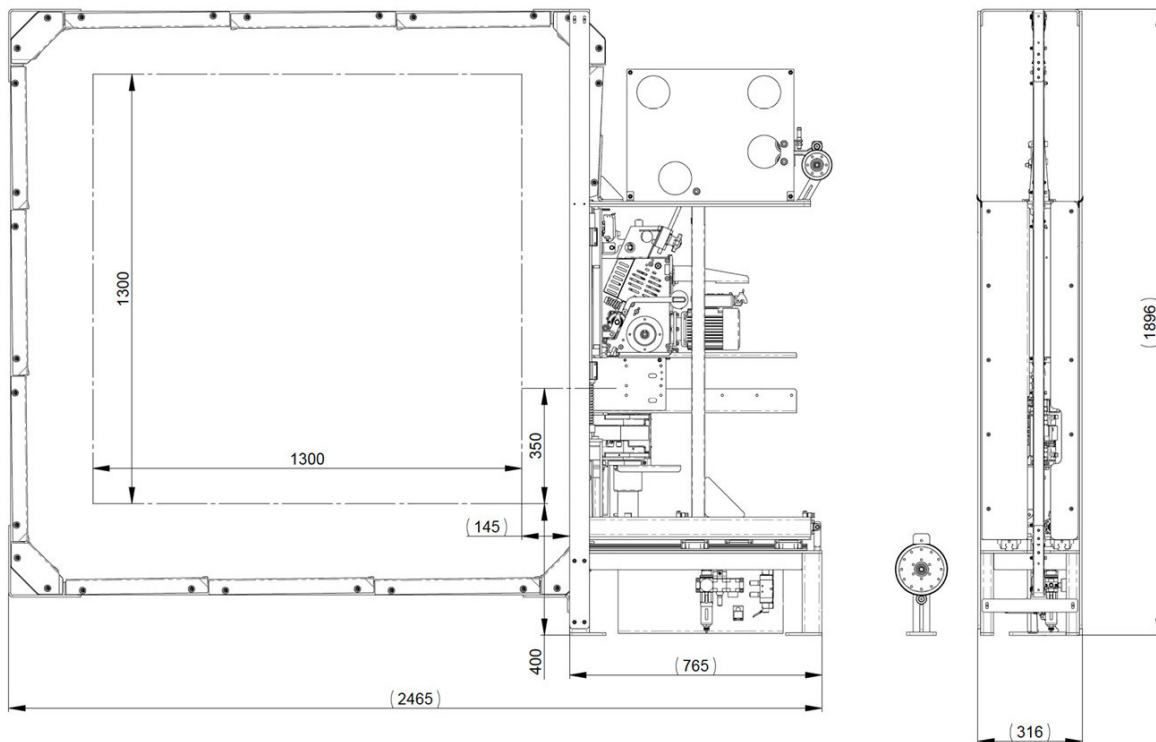

All dimensions shown in mm.

The company reserves the right to make technical alterations without prior notification.
©2024 Signode Industrial Group LLC / ID-809 / R-240108 / www.signode.com
For queries please contact Signode Industrial Group LLC at marketing@signode.com

