

# TSM-3000 EP

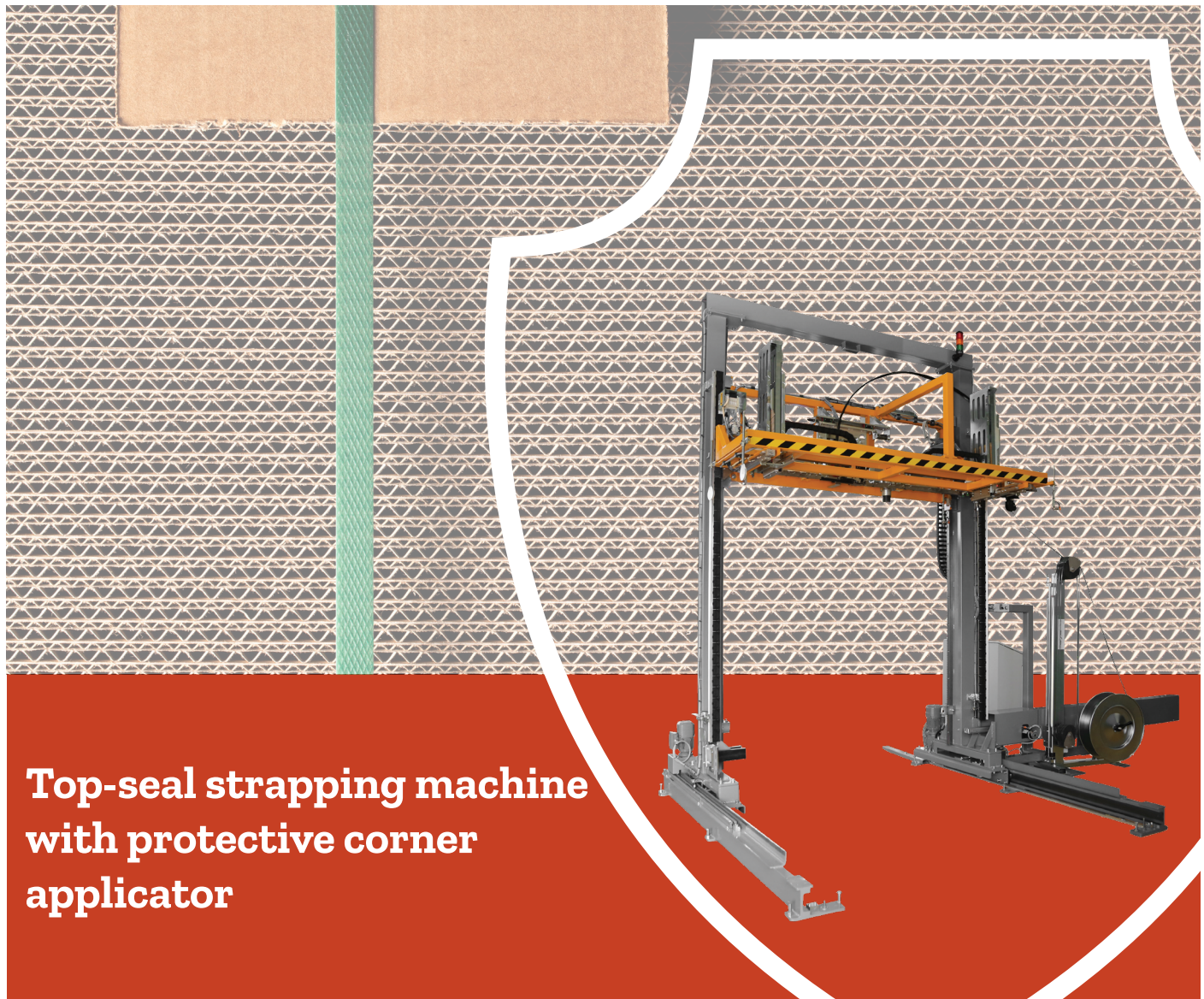

**Top-seal strapping machine  
with protective corner  
applicator**

## **Optimize Performance**

For maximum flexibility,  
highest productivity  
and performance

## **Higher Flexibility**

Low height and  
adjustable speed of  
bayonet and telescopic  
strap chute

## **High Speed Productivity**

Automatic strap feed  
and take-up with smart  
dispenser

## **Low Cost Ownership**

Robust machine design  
with low maintenance  
to minimize costs

# TSM-3000 EP

## Top-seal strapping machine with protective corner applicator

### TSM Machine / Features and Benefits

The modular design allows the range to use various strapping head types to be used with a machine design. This possibility for flexible head integration allows a large field of applications to be covered as well as being able to use flat and embossed plastic strap with friction weld technology.

- **High speed productivity**  
Intelligent dispenser with auto strap feed-up and re-feed from dispenser into sealer for medium and light duty heads.
- **Higher flexibility**  
Low height of bayonet and adjustable speed for customisation and higher throughputs
- **Higher performance**  
Floating head carriage for consistent and high retained strap tension on the product.
- **Reduced operator training needs**  
7" HMI operator touch screen for intuitive operation and simplified trouble shooting.



### Flexible production options

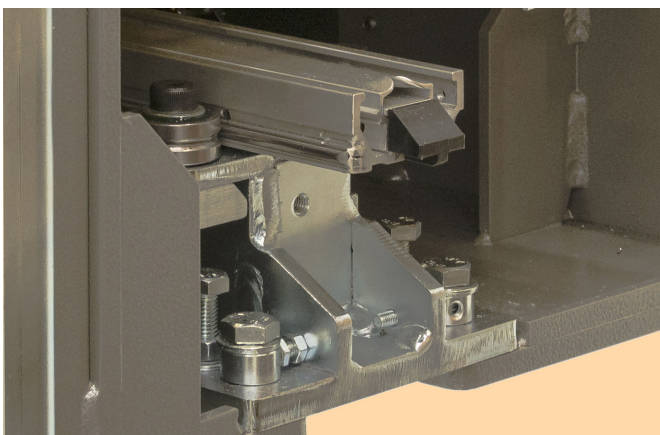

Low height bayonet or special protected bayonet for flexibility. Adjustable speed of bayonet for higher customisation and higher throughputs. Full-length strap-flaps on bayonet for increased reliability.

### Intuitive HMI display panel



An icon driven control panel that provides step by step prompts for easy and intuitive set up, with minimal language used, for simple control of all functions from a single panel.



## Strapping Head / Features and Benefits

- High performance**  
 Head carriage located on top of load equipped with model H3000 strapping head for high applied and retained strap tension on the load.
- High seal efficiency**  
 Friction weld technology, immediately available, no pre-heating time.
- Increased durability**  
 Durable and robust design and components for highest availability.
- Reduce Downtime**  
 Strapping head design can be serviced conveniently and quickly.

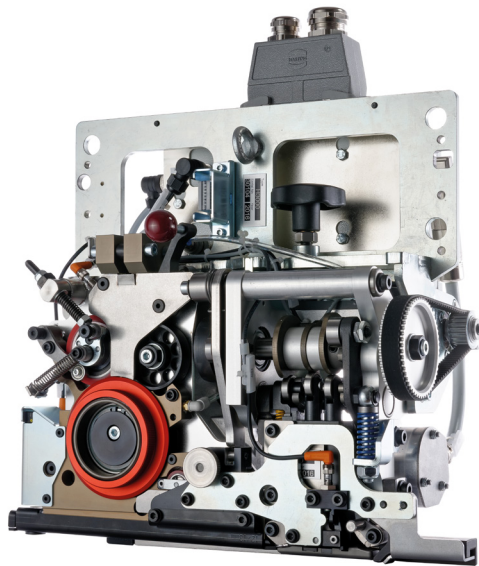

### Improved head carriage

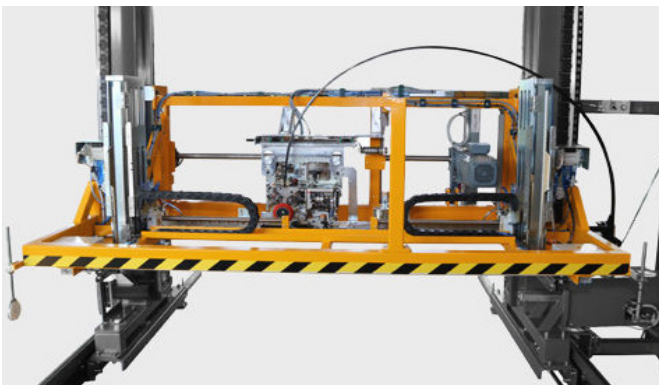

Fast variable speed drive motor with three-fold safety level on lifting chains. Lightweight space-frame model for high speed productivity. Optional heavy duty compression platen and top edge-protection applicator available.

### Accumulating strap dispenser



Standard dispenser for medium and heavy duty applications. Jumbo dispenser station option for maximum machine uptime.

# TSM-3000 EP

## Top-seal strapping machine



### Technical Specifications and Dimensions

Strapping Head	H3000
Carriage Speed	160mm/second
Strap Size & Type	9mm - 16mm Polypropylene and Polyester
Strap Tension (N)	200 - 3000
Sealing Method	Friction Weld
Conveyor / Conveying Height	Minimum 300mm (bayonet) Minimum 380mm (closed chute)
Chute Types	Bayonet for pallets Closed chute for packages
Protective Corner System	Pneumatic operated cardboard corner applicator (L=100mm)
Compression Force (Vertical)	600kg Max
Electric Supply	400V 3Ph 50Hz
Consumption (kVA)	2 - 3
Control Voltage	24V DC
Throughput	70 bundles per hour @ 18m/min conveyor
Machine Weight (kg)	1800
Strap Coil	406mm (16") Core
Operator Console	Free standing
Package Size (mm) Height x Width	1350x1250, 1850x1450, 2350x1650

### Standard Features

- Machine frame column design
- Steel carriage construction
- Protective corner feeders
- Strapping head floating design
- Rack drive system
- Vertical electric package compression
- Telescopic strap chute
- Free standing operator station
- Siemens S7 PLC controlled
- Free standing strap dispenser
- Automatic strap end detection

### Available Options

- H6500 heavy-duty strapping head
- Bayonet light barrier pallet check
- Electric powered rail movement system
- Strap end pre-warning
- Jumbo strap coil dispenser
- Air conditioning unit

