

# HE1M-AB Unitizer



## Horizontal Endsealer Strapping Machine with Automatic Strap Feed

### Cost Savings

Allows for a variety of strap types to be used for product applications

### Soft-Strap Application

Designed for compressable or unstable loads with smooth strap application

### Low Cost of Ownership

Simple sealing head with only a few moving parts and low maintenance

### Easy Integration

Having no strap chute, machines can be easily integrated into existing conveyor line

# HE1M-AB Unitizer

## Horizontal Endsealer Strapping Machine with Automatic Strap Feed

### Model Information

Model	Strap Beams	Strap Dispensers
HE1M-AB	1	2



### Machine Features and Benefits

#### ■ Strap Application

Effortlessly enveloping the product with precision, our innovative strap application system ensures high availability, seamless positioning of straps, and exceptional throughput.

#### ■ No Strap Arch

Few wearing parts, easily exchangeable. Direct brushless drives for head carriage, and bayonet for less service needs and longer operating life.

#### ■ Simple Design

Designed for efficiency and durability, the sealing head has a simplistic design with minimal moving parts reducing servicing and maintenance requirements. By prioritizing simplicity, operational costs decrease while maintaining performance, seamless functionality and long-term reliability.

#### ■ Increased Uptime

Equipped with dual strap coils per strapping line, the system extends operational efficiency with double the run length between coil changes. This innovative design increases productivity by minimizing downtime, providing uninterrupted performance for your packaging needs.

### Cost Savings

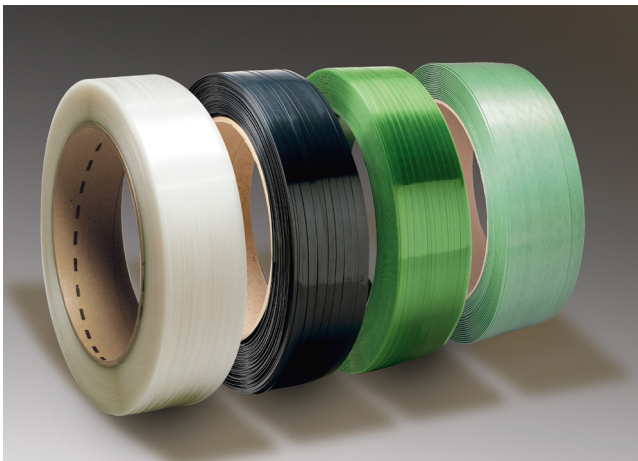

A variety of strap sizes can be used and selected for the product application, with cost savings on consumable materials.

### High Throughput

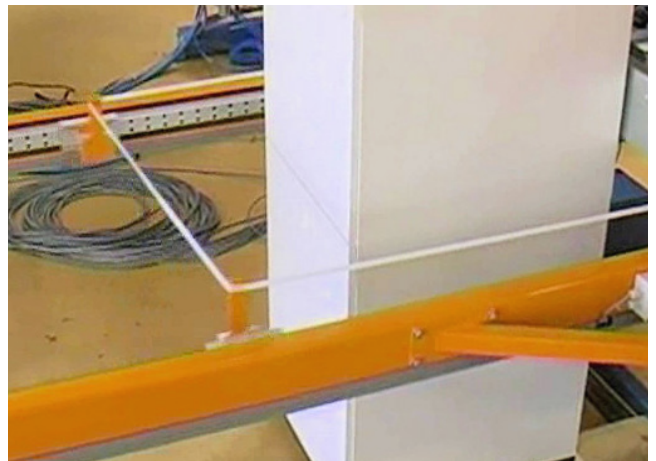

Strap is applied by the movement of the extension arm finger guides wrapping the strap around the product. Very accurate positioning of the strap placement.

## Sealer Head / Features and Benefits

- High Performance**  
 Having few moving parts allows the head to perform a fast 6 second cycle time.
- Modular Design**  
 The sealer head consists of two major assemblies. The welding unit and the pressing unit
- Low Maintenance**  
 The sealer head required no lubrication. All bearing are sealed design. occasional cleaning is all that is needed.

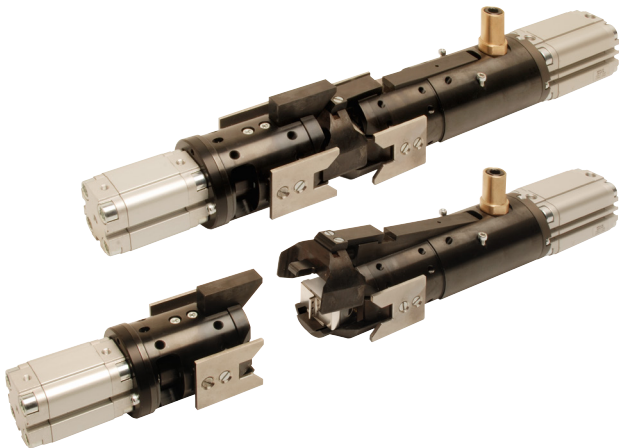

## Machine Options

- Strap tension unit
- Strap end pre-signal
- PET Strapping Kit
- Motorized movement of machine
- Beam protection
- Fast Beam movement
- Head protection plate

## Low Maintenance Cost

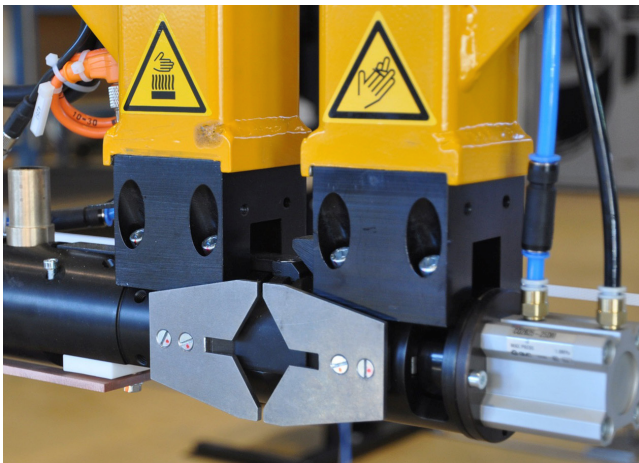

Simple sealing head with few moving parts and low maintenance operation.

## Inline Strapping Integration



Endsealers can be easily integrated into existing conveyor lines. Machines use very little floorspace to operate.

# HE1M-AB Unitizer

## Horizontal Endsealer

### Strapping Machine



### Machine Layout

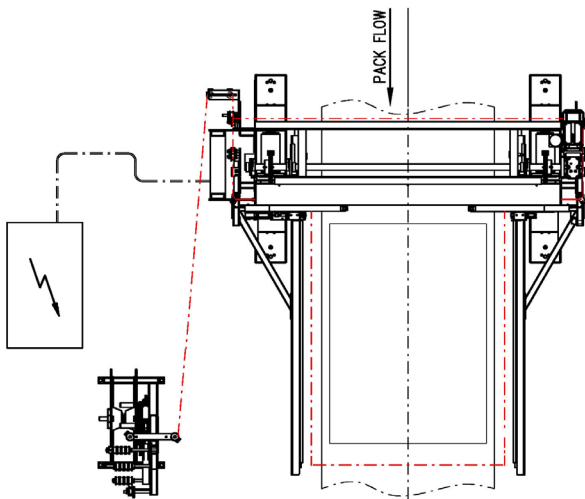
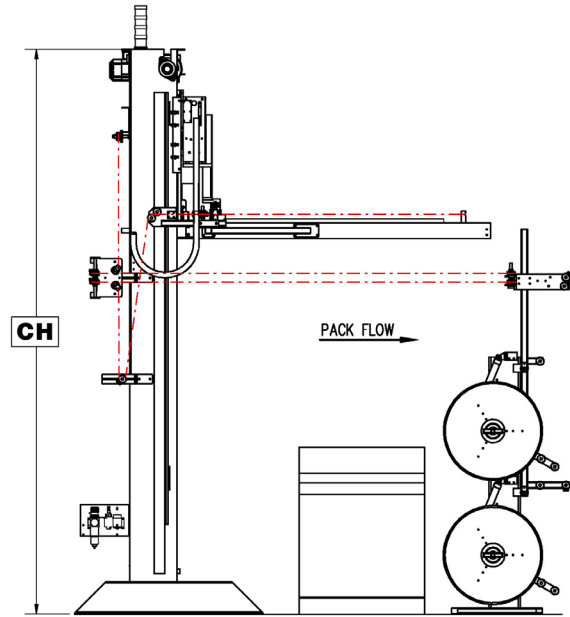
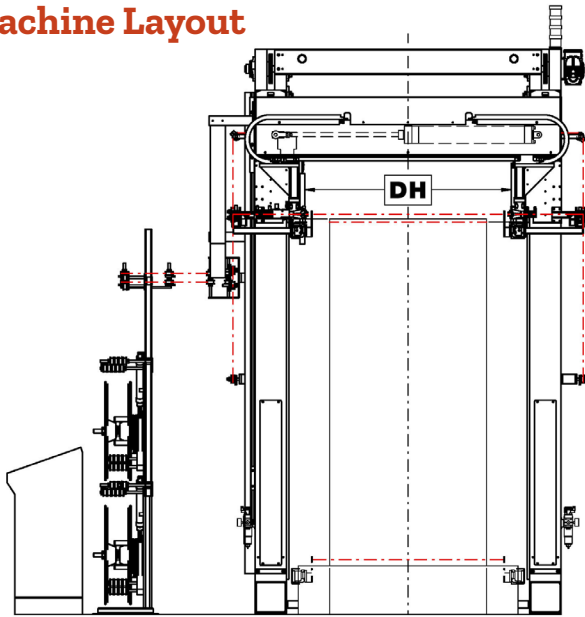

### Technical Specifications

<b>Strapping</b>	5 -16mm Polypropylene (PP) 5 -13mm Polyester (PET)
<b>Strap Tension</b>	0-400 N (retained tension on product)
<b>Strap Cycle Time</b>	6 sec. (PP strap), 7 sec. (PET strap)
<b>Tension Stroke</b>	Flexible, adapted to product
<b>Vertical Speed</b>	100 mm (3.9") per second Optional 300 mm (11.8") per second
<b>Sealing Method</b>	Heat seal for PP strap (PET optional)
<b>Min Strapping Height</b>	40 mm (1.6") above conveyor 350 mm (13.8") above floor
<b>Max Strapping Height</b>	Up to 2900 mm (114.2")
<b>Strap End</b>	Automatic end detection
<b>Strap Dispenser(s)</b>	2 per strap, flexible location
<b>PLC Control</b>	Simatic S7-1212C
<b>Electrical Supply</b>	400VAC, 3Ph, 50Hz 460VAC, 3Ph, 60Hz
<b>Control Voltage</b>	24 VDC
<b>Pneumatic Supply</b>	6 bar, 75 lpm (95 psi, 2.65 cfm)
<b>Machine Weight</b>	700 - 1000 kg (1543 to 2204 lbs)

Machine Layout	Distance Between Heads (DH)	Column Height (CH)	
		3600mm (141.7")	4000mm (157.5")
1811.021.071	900mm (35.4")	•	•
1811.021.072	1100mm (43.3")	•	•
1811.021.073	1300mm (51.2")	•	•
1811.021.074	1500mm (59.1")	•	•
1811.021.075	1700mm (66.9")	•	•